



**City of Dallas**

# **Commercial Motor Vehicles Code Amendment**

DCA 223-003

**Zoning Ordinance Advisory  
Committee (ZOAC)**

**July 23, 2024**

Michael Wade, Sr. Planner  
Planning & Development  
City of Dallas

Consideration of amending Chapters 51 and 51A, the Dallas Development Code, regarding the definition of oversized motor vehicles and oversized trailers.

# Presentation Overview



1. Background
2. Analysis
3. Proposal
4. Discussion





Voting on a recommendation to CPC.

---





**GVWR**  
Gross Vehicle  
Weight Rating



**TW**  
Tongue Weight



**GCWR**  
Gross Combined  
Weight Rating

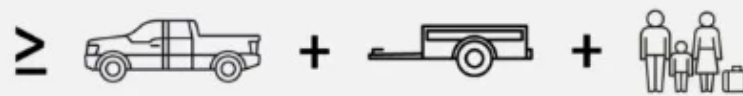

**CURB  
WEIGHT**

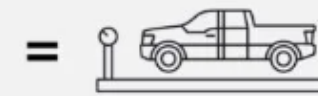

**GAWR**  
Gross Axle  
Weight Rating

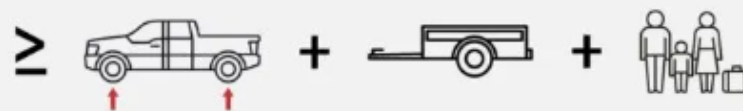

**DRY  
WEIGHT**



**GTW**  
Gross Trailer  
Weight



**PAYLOAD** =

“carrying capacity”  
“rated capacity”





## December 6, 2022: Initial presentation

Code Compliance presented to the Quality of Life, Arts, and Culture Committee about difficulty enforcing the weight maximum on vehicles parked in front driveways in Section 51A-4.217(b)(6) *Accessory Outside Storage*.





## Issues

- Currently, a motor vehicle over 32 feet long or 1.5 tons (3,000 pounds) of carrying capacity may not be parked in any primary yard\*\*.
- Carrying capacity information is difficult to ascertain. Weight is...
  - ...not displayed outside the vehicle;
  - ...not corresponding with vehicle model names;
  - ...inconsistently reported by manufacturers;
  - ...not verifiable by a Code Compliance officer on the spot.
- The common use of large pickup trucks as personal/non-commercial vehicles is highlighting this regulation.



# Background

1. Background
2. Analysis
3. Proposal
4. Discussion



## Examples of inappropriate vehicles in front yards of Dallas





# Background

1. Background
2. Analysis
3. Proposal
4. Discussion



Examples of common commercial and passenger vehicles.



# Background

1. Background
2. Analysis
3. Proposal
4. Discussion



Big and Texan?



Disruptive?



?



# Background

1. Background
2. Analysis
3. Proposal
4. Discussion



Big and Texan?



Disruptive?





## Regulatory purpose:

- Protect the reasonable enjoyment of residential areas by prohibiting vehicles that introduce major noise, dirt, or visual nuisances.
- Delineate clearly which vehicles are intended to be served by certain other land uses.





## **Not the regulatory purpose:**

- Prohibit all vehicles used for commercial purposes. (Ex. Bob's Plumbing using a small Ford Ranger)
- Keep residents from a reasonable use of their property. (Ex. Re-examining RV or boat storage policies)































NOTE: For the purpose of *this* regulation, we are not considering the role of vehicle weights on street degradation and maintenance. Vehicles that make a true difference on street quality are regulated through Chapter 28, directing them to designated truck routes and highways.



# Analysis

1. Background
- 2. Analysis**
3. Proposal
4. Discussion



<b>Class 1 - 6,000 lbs &amp; Less</b>     Minivan    Cargo Van    SUV    Pickup Truck	Yes
<b>Class 2 - 6,001 to 10,000 lbs</b>     Minivan    Cargo Van    Full-Size Pickup    Step Van	
<b>Class 3 - 10,001 to 14,000 lbs</b>     Walk-in    Box Truck    City Delivery    Heavy-Duty Pickup	Analyze
<b>Class 4 - 14,001 to 16,000 lbs</b>    Large Walk-in    Box Truck    City Delivery	
<b>Class 5 - 16,001 to 19,500 lbs</b>    Bucket Truck    Large Walk-in    City Delivery	
<b>Class 6 - 19,501 to 26,000 lbs</b>     Beverage Truck    Single-Axle    School Bus    Rack Truck	No
<b>Class 7 - 26,001 to 33,000 lbs</b>     Refuse    Furniture    City Transit Bus    Truck Tractor	
<b>Class 8 - 33,001 lbs &amp; Over</b>     Cement Truck    Truck Tractor    Dump Truck    Sleeper	

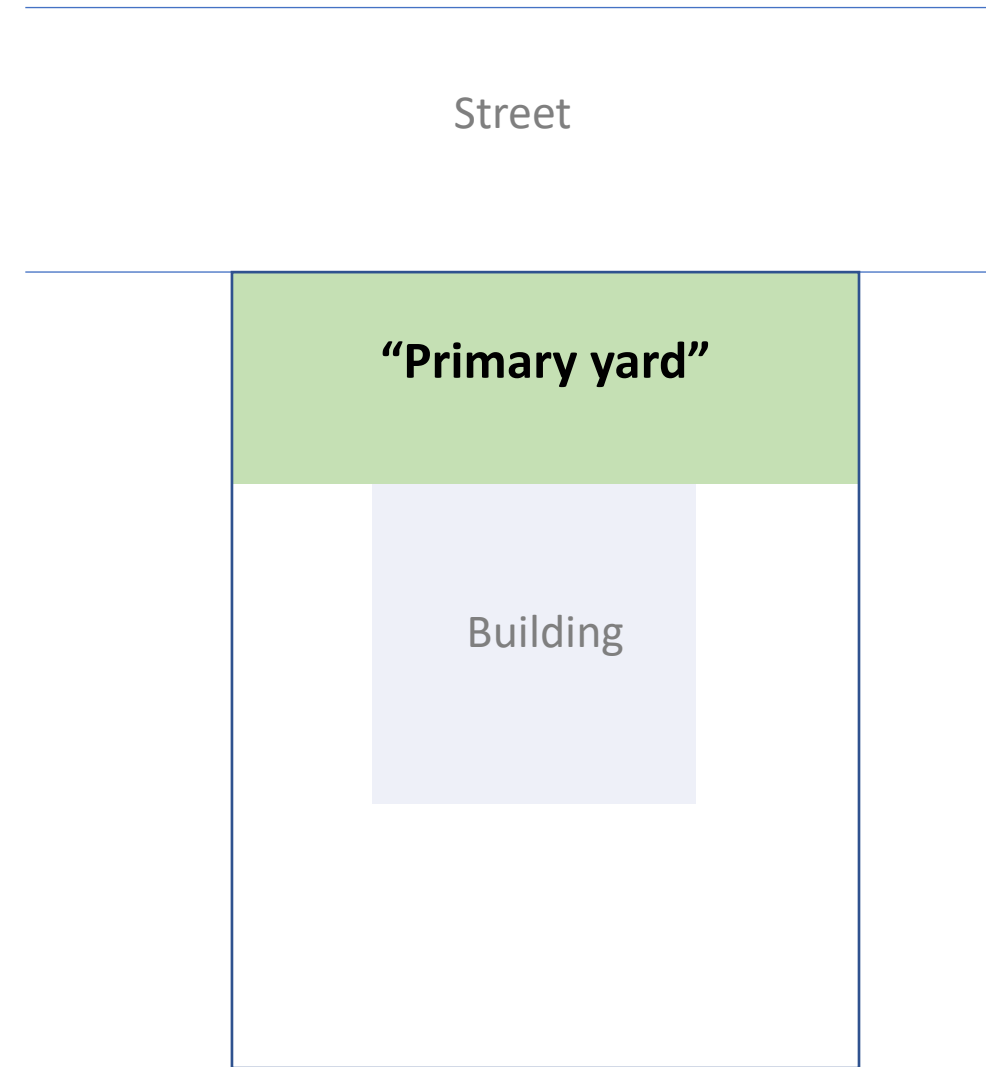



## Analysis included:

- Federal regulations (federal highways and roads)
- State regulations (state highways and roads)
- Dallas regulations
  - **Chpt. 51A Development Code** (private property in general);
  - **Chpt. 28 Transportation Code** (public right-of-way in general);
  - Chpt. 44 Taxation (vehicle rentals)
- Peer cities (Houston, Ft. Worth, McKinney, etc.)
- Vehicle specifications and uses
- Interdepartmental review and research (Code, DDOT)



# Analysis: Chapter 51A

1. Background
- 2. Analysis**
3. Proposal
4. Discussion



## 1. Regulates vehicles parked in the primary yard:

- o *Accessory Outside Storage* – 4.217(b)(6)
  - Vehicles over **32 feet** long or **1.5 tons (3,000 pounds)** in rated capacity are prohibited (incl. RVs)



2024 Ford F-250  
Payload – 4,268



2024 Chevrolet Silverado 2500  
Payload – 3,504 - 7,290



Fleetwood Southwind  
32 feet long





# Analysis: Chapter 51A

1. Background
2. Analysis
3. Proposal
4. Discussion



## 2. Limits land uses to serving vehicles under 6,000 pounds or 15 passengers (“the weight of each vehicle”):

- o Auto service center – 4.210(b)(3)
- o Commercial parking lot or garage – 4.210(b)(9)
- o Vehicle display, sales, and service – 4.210(b)(31) (weight only)



Chevy Silverado 2500  
CW – 6,074 / GVWR – 10,450



2025 Cadillac Escalade ESV 4WD  
CW – 6,188 / GVWR - ?



Bentley Mulsanne  
CW – 5,919 / GVWR – 6,174



2023 GMC Savana 15-passenger  
CW – 6,074 / GVWR 8,600





## 3. Limits land uses to serving larger “commercial motor vehicles”:

- *Truck stop* – 4.210(b)(30.1)
- *Commercial motor vehicle parking* – 4.210(b)(8.1)
- *Liquefied natural gas fueling station* – 4.210(b)(16.1)

COMMERCIAL MOTOR VEHICLE means a motor vehicle that:

- *...is designed or used for the transportation of cargo;*
- *...has a gross weight, registered weight, or gross weight rating in excess of 26,000 pounds; and*
- *...is not owned or operated by a governmental entity.*

\*26,000 pounds (assuming GCWR, vehicle + load + trailer):

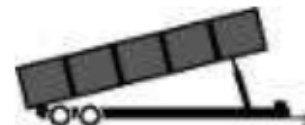

# Analysis: Chapter 28

1. Background
- 2. Analysis**
3. Proposal
4. Discussion



## 1. Defines “commercial vehicle” (Sec. 28-2):

- “...any vehicle that displays a valid commercial, truck, or truck-tractor state license plate.”
- (Irrelevant since the State discontinued this license plate)

## 2. Prohibits...

...commercial vehicles	from parking (etc.) on public right-of-way (Sec. 28-80)
...vehicles with capacity more than <b>1.5 tons</b>	from parking (etc.) along any residential block face (Sec. 28-81)
...vehicles with an actual load of <b>5,000 pounds</b>	from crossing certain bridges or traveling on roads other than truck routes (or state or federal highways) (Sec. 28-64/65)
...vehicles having a gross weight in excess of <b>6,000 pounds</b> , or a vehicle having an overall length in excess of 21 feet, or any trailer	from parking (etc.) in the Dallas Convention Center or the City Hall Parking Garage. (Sec. 28-124 and Sec. 28-128.3)





## The problem with weight:

- The great variety of custom builds makes exact weights difficult or impossible to determine, and the final weight is not displayed exterior to the vehicle.
- Example: F-150 XL (one of six F-150 trim types) has **4,147,200 possible build outs** (incl. cab and bed lengths, engine types, etc.) An F-150 XL can be heavier than a Super Duty F-250.
- More appropriate for Chpt. 28 than Chpt. 51A; weight is relevant when determining on which roads or bridges a vehicle may drive, but may not for parking in a yard.



Image and vehicle information from Consumer Guide Automotive and Ford.





## Proposal:

- Replace various lists of characteristics throughout Chpt. 51A with a new, clear term and definition using easily-ascertainable characteristics:
  - **“Oversized motor vehicle”**
    - More than 22 feet long, 8 feet wide, or 9 feet high (appropriate size that accommodates current personal vehicle preferences);
    - Two or more rear axles (clearly indicates heavy commercial use); or
    - Designed to transport more than 15 passengers.
  - **“Oversized trailer”**
    - Same dimensions but without motor power (accommodates a trailer intended for personal belongings, etc. but not transporting major loads)





## Typical semi-trailer dimensions:

- Length: 48' – 53'
- Width: 8'6" – 10'
- Height: 13'6"

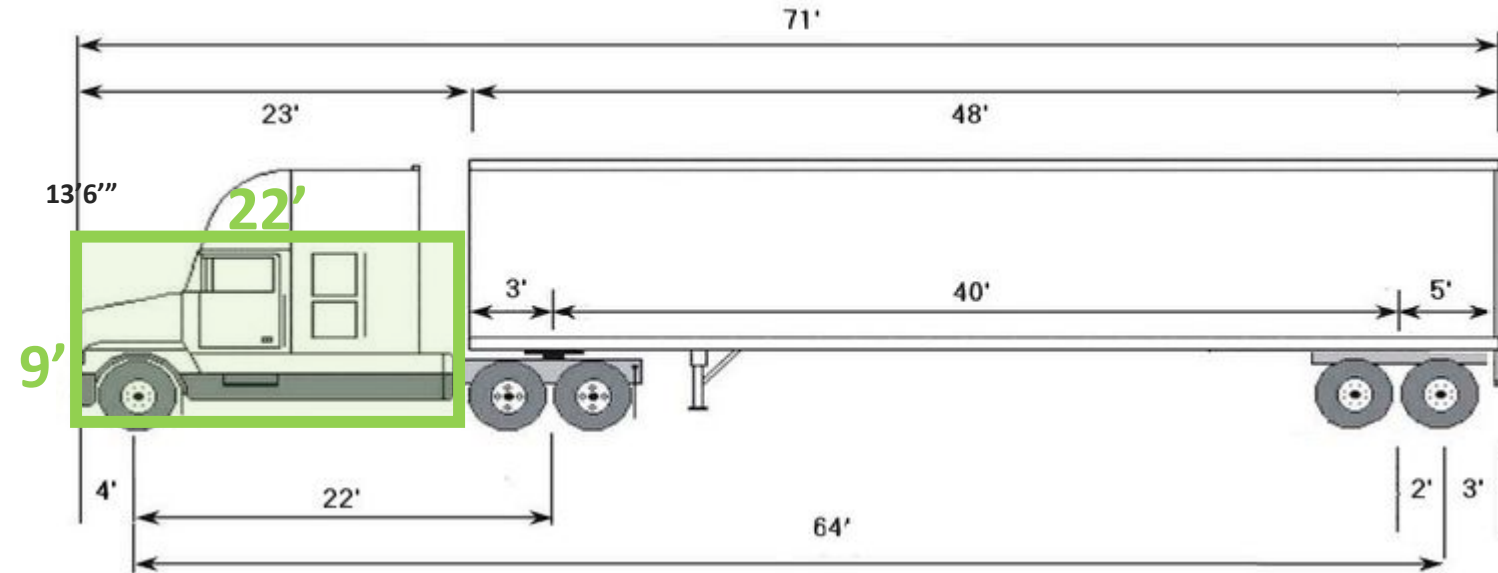

- For reference, these weigh around 60,000 to 80,000 pounds





## Example vehicles that are just under the proposed size limits for an “oversized motor vehicle”:



2024 For F-350 and F-450 Super Duty  
Length: 19.8-22 feet  
Width: 8 feet  
Height: 6.8 feet



2024 Ford F-550  
Length: 19.2-24 feet  
Width: ~6 feet  
Height: ~7 feet



2019 Mercedes-Benz Sprinter 15  
passenger van w/ high roof  
Length: ~22 feet  
Width: 7.6 feet  
Height: ~9 feet



## Proposal:

- Implement the *oversized motor vehicle* and *oversized trailer* terms to relevant land uses, streamlining land use provisions.
- Restructure Sec. 51A-4.217(b)(6)(E) for increased clarity (until the comprehensive code reform can make even bigger changes);
- Update relevant land uses to reflect practical use allowances and staff interpretations.
  - For instance, Sec. 51A-4.210(b)(31) *Vehicle display, sales, and service* is amended to clarify that rental operations are included along with sales, aligning with current staff interpretation.







## Proposal:

- Note: The 4.210(b)(8.1) *Commercial Motor Vehicle Parking* land use will keep its label. The term still applies to the intent of this land use.

### (8.1) Commercial motor vehicle parking.

(A) Definition: A facility for the temporary, daily, or overnight parking of commercial oversized motor vehicles ~~as defined in the use regulations for a truck stop, and/or motor vehicles with two or more rear axles such as trucks, truck tractors, and similar vehicles,~~ for no charge or for a fee, regardless of whether that fee is charged independently of any other use on the lot, if the parking is not accessory to a main use on the lot.





## Next Steps

- City Plan Commission
- City Council
- Chapter 28 amendments (DDOT)





**City of Dallas**

# **Commercial Motor Vehicles Code Amendment**

DCA 223-003

**Zoning Ordinance Advisory  
Committee (ZOAC)**

**July 23, 2024**

Michael Wade, Sr. Planner  
Planning & Development  
City of Dallas



- **Accessory Outside Storage– 51A-4.217(b)(6)**

- Prohibits the placement of an item in the primary yard for a continuous period in excess of 24 hours unless it is:
  - (E)(iv)(aa) – A motor vehicle, including a truck, truck-tractor, bus, or recreational vehicle, that...
    - ...is operable;
    - ...has a valid state registration;
    - ...is parked on an approved surface (Chpt. 51A)
    - ...is not more than 32 feet long;
    - ...is not a truck, truck-tractor, bus, or RV with rated capacity over 1.5 tons
  - (E)(iv)(bb) – A boat, trailer, or RV that...
    - ...cannot be reasonably placed in another part of the property;
    - ...is parked on an approved surface;



# Analysis: Chapter 51A

1. Background
- 2. Analysis**
3. Proposal
4. Discussion



Several land uses refer to a “vehicle weight” (Curb weight? GVWR?) of 6,000 pounds or seating capacity of 15 passengers including driver:

- **Auto Service Center – 51A-4.210(b)(3)**

- Definition: A facility for the servicing or minor mechanical repair of motor vehicles....
- The servicing or repair of motor vehicles that weigh more than **6,000 pounds** or that have a manufacturer’s rated **seating capacity of more than 15 persons** is not permitted under this use.
- Otherwise facility is considered *Vehicle or engine repair or maintenance* [4.202(b)(14)]. (No size or weight restrictions)





Several land uses refer to “vehicle weight”, assuming Gross Vehicle Weight Rating (GVWR):

- **Commercial parking lot or garage – 51A-4.210(b)(9)**

- Definition: A vehicle parking facility that is operated as a business enterprise by charging a fee for parking.
- The parking of vehicles that weigh more than **6,000 pounds** or that have a manufacturer’s rated **seating capacity of more than 15 persons** is prohibited under this use in all areas of the city except the central business district.
- Otherwise facility is considered *Commercial motor vehicle parking* [4.210(b)(8.1)], for use by:
  - “Commercial motor vehicle”: designed for transportation of cargo, weighs 26,000 pounds, and is not owned by govt;
  - Motor vehicles with 2+ rear axles;
- **Notice the gap between 6k lbs/15 passengers and 26k lbs/2 rear axles**





Several land uses refer to “vehicle weight”, assuming Gross Vehicle Weight Rating (GVWR):

- **Vehicle display, sales, and service – 51A-4.210(b)(31)**

- Definition: A facility for the display, service, and retail sale of new or used automobiles, boats, trucks, motorcycles, motor scooters, recreational vehicles, or trailers.
- The weight of each vehicle displayed or sold under this use may not exceed **6,000 pounds**.
- Otherwise facility is considered *Machinery, heavy equipment, or truck sales and service* [4.202(b)(10)]: “A facility for the display, sales, and service of machinery, heavy equipment, or trucks.”



# Board Special Exception



An applicant is allowed to pursue a special exception from the **Board of Adjustment**. This provides for properties without access to outside storage beyond the primary yard to seek relief while still preserving a public hearing requirement and includes neighborhood input.

(vi) The board may grant a special exception to the additional provisions of this subsection relating to accessory outside storage in the primary yard or on a front porch of a residential building when, in the opinion of the board, the special exception will not adversely affect neighboring property.

